

Your Partner in Power Industry

Company Profile G – Team a.s.



Equipment for power and heat generation industry

TEPLOTNÍ ČERPEL
ÚSTUPNÍ PÁRA
PROTITLAK





Content:

About G-Team, a.s.	3
Fields of application.....	4
Micro Steam Turbines	5
Control valves.....	13
Desuperheaters.....	15
Bypass valves	17
Check (non-return) valves	18
Design engineering	19
Experimental and Development Department	21
Installation	23
Production	25
Contacts	28



About G-Team, a.s.

G-Team, a.s. founded in 1992 is an engineering and manufacturing company. From its beginning, G-Team is involved in the area of heating plant industry and fossil-fuel power stations and nuclear power plants. We are the leading supplier in power generation sector specializing in steam and condensate equipment. Our broad spectrum of supplies and production covers boilers, steam turbines, valves, pipeline systems, drainage and condensate systems. Using an integrated approach in production process includes customer support in engineering (projects) and wide range of services, in particular installation of machine rooms, boiler plants and pipeline systems.



Identification data:

Legal form: Join-Stock Company

Company registered in the Commercial Register maintained by the Regional Court in Plzeň, Section B, Insert 1319

Ident. No. (IČO): 45358028, VAT ID (DIČ): CZ 45358028



Fields of application:

- Fossil-fuel and nuclear power plants
- Water industry
- Chemistry industry
- Food and Beverage industry

Energy Units:

- Generation units up to 25 MW
- Microturbines up to 5 MW
- Bypass stations
- Reducing stations
- Steam generators
- Oil systems
- Cogeneration units
- Monitoring

Engineering:

- Studies on energy savings
- Energy equipment design
- Turnkey projects
- Energy audits
- Consulting

Valves:

- Valves for steam and condensate in generating and industrial installations
- Control and shut off valves, check valves
- Reducing valves
- Quick-closing valves
- Drain and blowdown valves
- Safety valves
- Ball valves
- Check (non-return) valves
- HP and LP steam separators
- Steam traps

Services:

- Energy equipment installation
- Pipeline system installation
- Spare parts supply
- Project Financing
- Trainings within G-Team Academy

Measurement and control:

- Control and optimization of energy processes
- Control of pressure, temperature and amount
- Measurement of energy quantities
- Control, regulation and safety systems of microturbines
- Occupational health and safety management systems (BOSP)
- Installation and setting of servo-actuators
- Vibration and movement of rotary machines – Reutlinger
- Diagnostics of steam traps operation

Micro Steam Turbines (TR)

Classification

TR with frequency converter TR Hi 150:

- G-Team, a.s. self-construction
- gearbox replaced with high-frequency generator and frequency converter
- compact design
- only to drive high-frequency generator integrated in turbine

TR with “overhung” impeller TR100, TR320, TR560 and TRM3:

- G-Team, a.s. self-construction
- simple – modular construction, low installation costs and quick economic pay off solution
- efficiency optimization due to partial arc of admission
- compact design
- high overall thermal efficiency
- service life – min. 25 years
- simple operation and maintenance
- suit to drive generators, feedwater pumps and ventilators
- simple installation

TR with “between bearings” impeller TRm:

- classic construction
- long service life
- mechanical and electronic regulation
- multiple stages of blades
- suit to drive generators, feedwater pumps, ventilators and sugar-cane mills

Types:

TR Hi 150 TR100 TR320 TR560 TRM3 TRm

For mechanical drives	✗	✓	✓	✓	✓	✓
To drive generator	✓	✓	✓	✓	✓	✓
With integrated gearbox	✗	✓	✓	✓	✓	✗

Maximum operating parameters

Inlet steam pressure up to [MPa (a)]	4	4	9	4	9	6
Inlet steam temperature up to [°C]	420	420	550	420	550	450
Output (Exhaust) steam pressure up to [MPa (a)]	0,6	0,6	2,5	0,07–1,4	0,07–1,4	0,9
Power output up to [kW]	80	150	700	3 000	5 000	1 200

Model



p. 7



p. 8



p. 9



p. 10



p. 11



p. 12



Equipment for power and heat generation industry

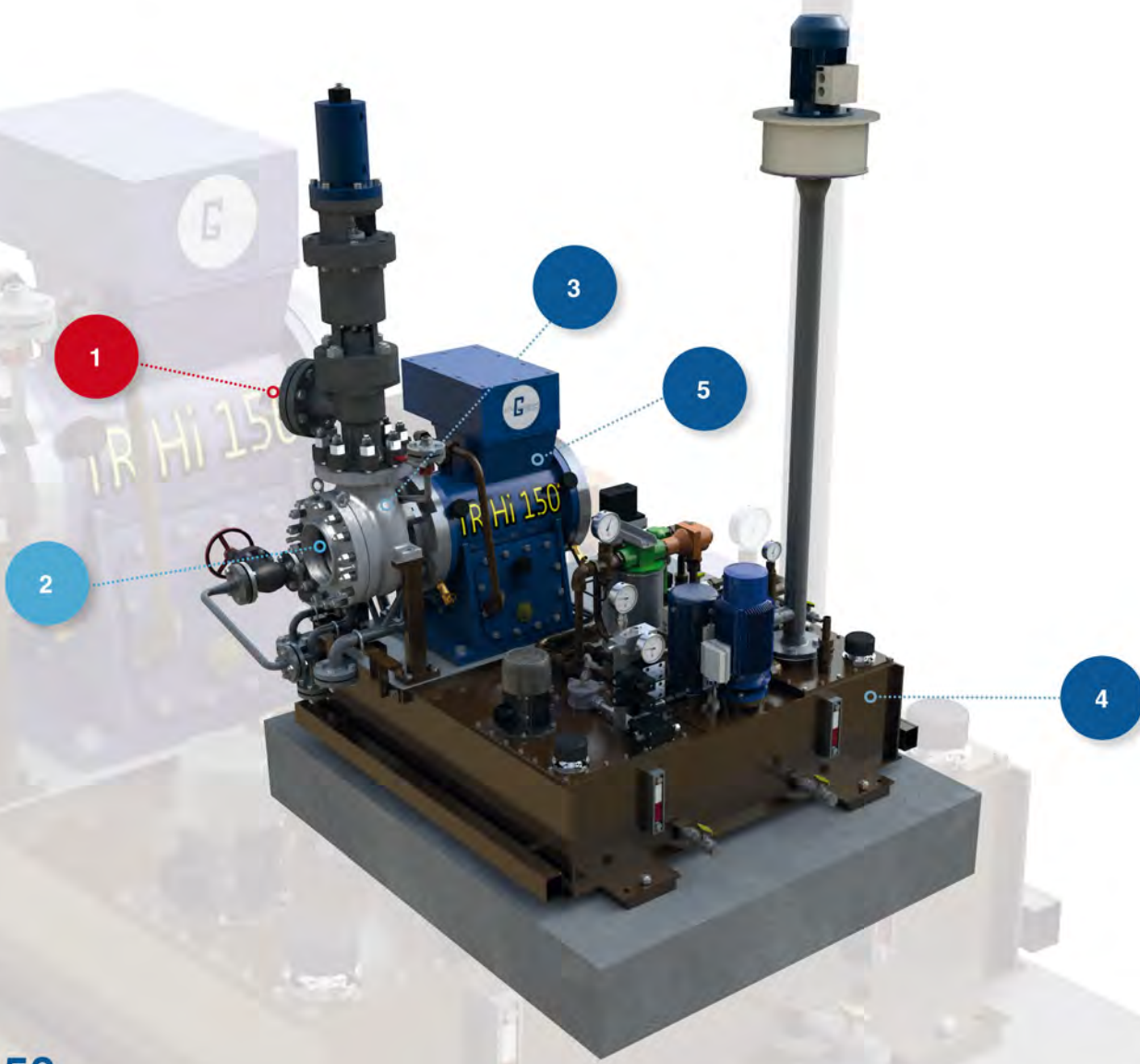

- Microturbine TR Hi 150 is intended and designed for pressure reduction of water vapour and extremely low steam flow complying the requirements for safe and mechanical operation together with high efficiency. Turbine casing with electric generator stator form a unit without coupling and secondary rotary parts.
- Impeller is “overhung” type on rotor of high-frequency electric generator. Mechanical face seals provided reduce steam leaks effectively. Complete oil system is included to supply lubricating and governor oil.
- Microturbine is used for automatic steam reduction to required value in connection with steam extraction which determines electric output of generator.

TR HI 150

1/ Steam inlet	Power output	up to 80 kW
2/ Steam outlet	Generator speed	30 000 rpm
3/ Turbine casing	Inlet steam pressure	up to 4,0 MPa (a)
4/ Base frame	Exhaust steam pressure	up to 0,6 MPa (a)
5/ High-frequency generator	Inlet steam temperature	up to 420 °C



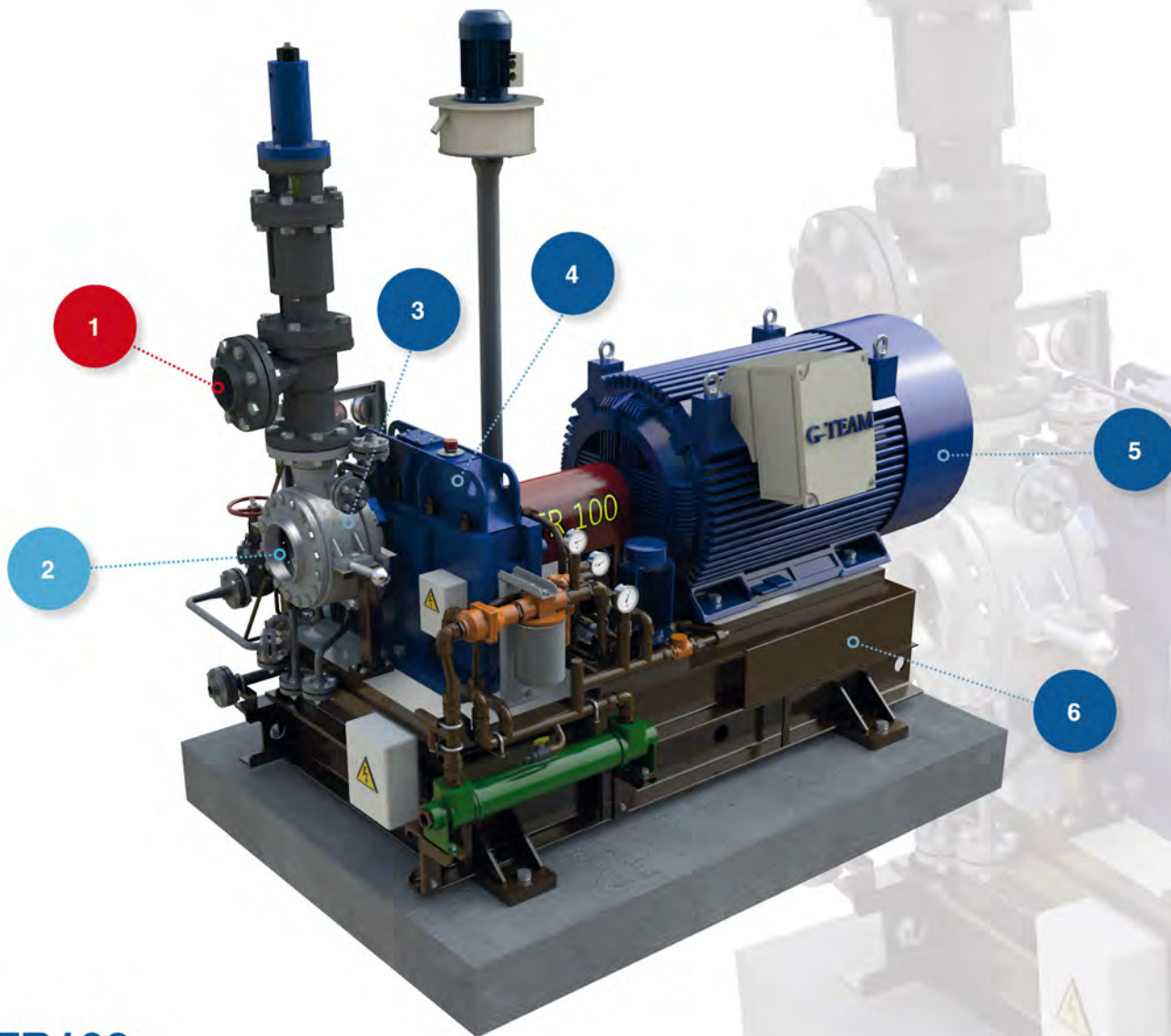

- Microturbine TR100 is particularly designed to drive generators with following power generation.
- Gearbox with fixed-on stator of TR100 reduces the speed of impeller to comply with the electric asynchronous generator speed. Base frame including entire oil system and gearbox connected to propelled machine by means of flexible coupling. Mechanical face seals provided reduce steam leaks effectively.
- Microturbine is used for automatic steam reduction to required value in connection with steam extraction which determines electric output of generator.

TR100

1/ Steam inlet	Power output	up to 150 kW
2/ Steam outlet	Generator speed	3 000 rpm
3/ Turbine casing	Inlet steam pressure	up to 4,0 MPa (a)
4/ Gearbox	Exhaust steam pressure	up to 0,6 MPa (a)
5/ Asynchronous generator	Inlet steam temperature	up to 420 °C
6/ Base frame	Partial admission of impeller	





- Microturbine TR320 is particularly designed to drive generators with following power generation.
- Gearbox with fixed-on stator of TR320 reduces the speed of impeller to comply with the electric asynchronous generator speed. Base frame including entire oil system and gearbox connected to propelled machine by means of flexible coupling. Mechanical face seals provided reduce steam leaks effectively.
- Microturbine is used for automatic steam reduction to required value in connection with steam extraction which determines electric output of generator.

TR320

1/ Steam inlet	Power output	up to 700 kW
2/ Steam outlet	Generator speed	3 000 rpm
3/ Turbine casing	Inlet steam pressure	up to 9,0 MPa (a)
4/ Gearbox	Exhaust steam pressure	up to 2,5 MPa (a)
5/ Asynchronous generator	Inlet steam temperature	up to 550 °C
6/ Base frame	Partial admission of impeller	



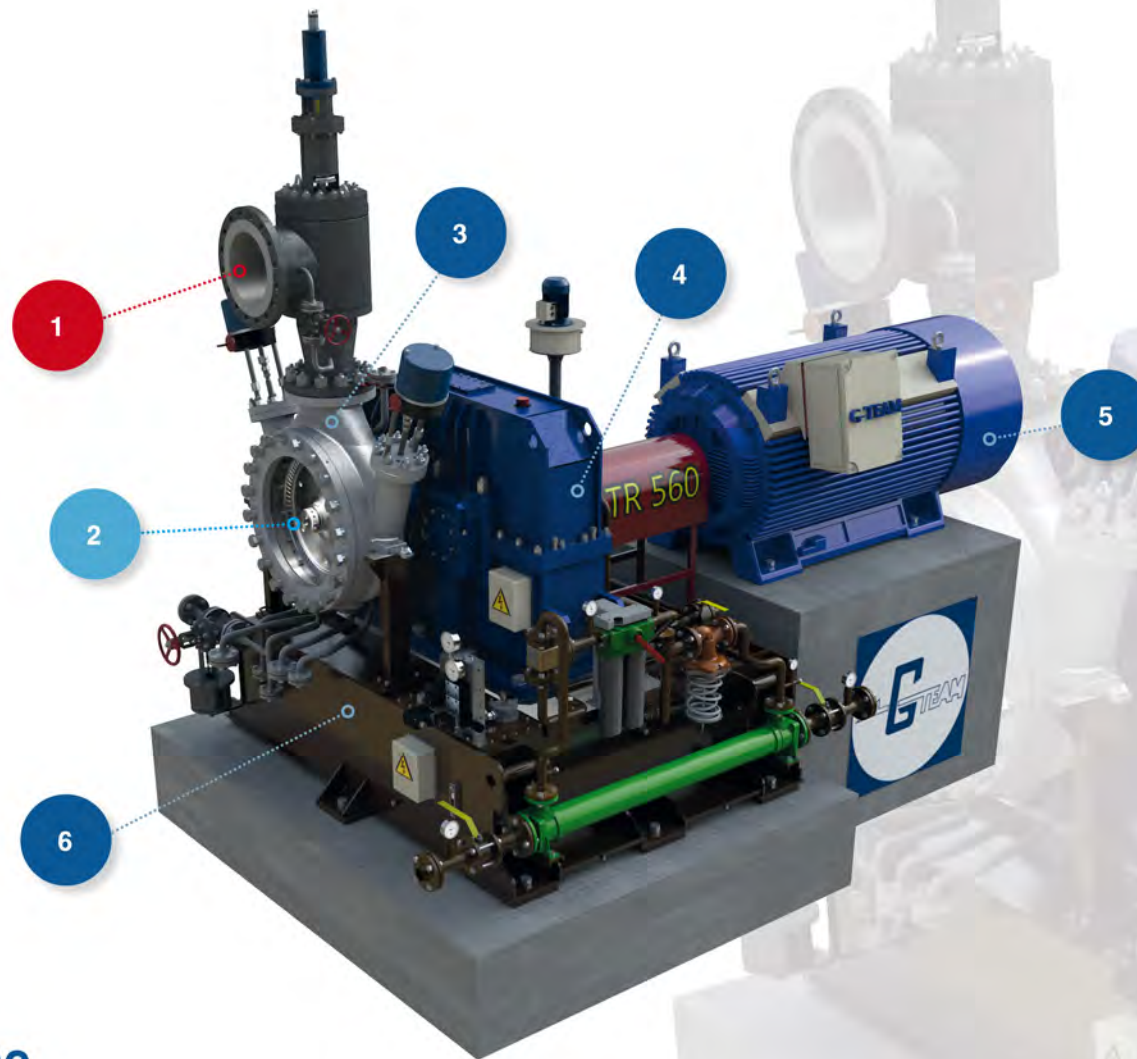

- Microturbine TR560 is particularly designed for isentropic enthalpy drop Δh higher than 120 kJ·kg⁻¹ with two possible partial admissions. Machine unit may be used in both backpressure and condensate system.
- Gearbox with fixed-on stator of TR560 reduces the speed of impeller to comply with the electric asynchronous generator speed. Base frame including entire oil system and gearbox connected to propelled machine by means of flexible coupling. Driven machine is separately placed on concrete foundation. Mechanical face seals provided reduce steam leaks effectively.
- Microturbine TR560 may be used in both systems – backpressure and condensate. The choice depends on the customer and his needs leading to heat and power generation or to use microturbine TR just for power generation.

TR560

1/ Steam inlet	Power output	up to 3 000 kW
2/ Steam outlet	Speed	1 500 rpm
3/ Turbine casing	Inlet steam pressure	up to 4,0 MPa (a)
4/ Gearbox	Exhaust steam pressure	up to 0,07-1,4 MPa (a)
5/ Synchronous generator	Inlet steam temperature	up to 550 °C
6/ Base frame	Partial admission of impeller	



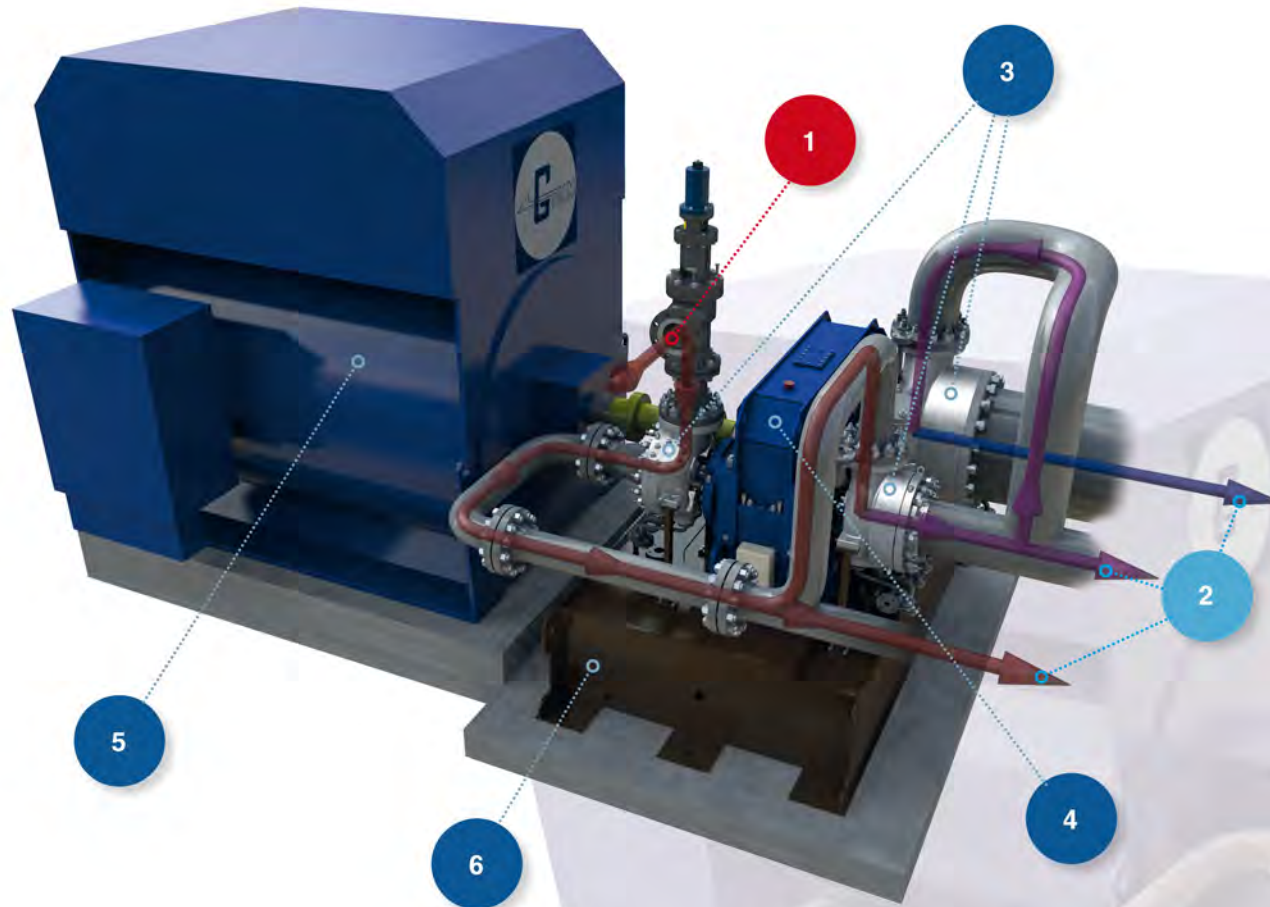

- Microturbine TRM3 is particularly designed for isentropic enthalpy drop Δh higher than 400 kJ/kg with possible one up to three steam extractions. Machine unit may be used in both backpressure and condensate systems.
- Turbine casings I., II. and III. stage are fixed to gearbox to reduce turbine wheels speed to comply with generator speed. Base frame including entire oil system and gearbox connected to propelled machine by means of flexible coupling. Driven machine is separately placed on concrete foundation. Mechanical face seals provided reduce steam leaks effectively.

TRM3

1/ Steam inlet	Power output	up to 5 000 kW
2/ Steam outlet	Speed	1 500 rpm
3/ Turbine casing	Inlet steam pressure	up to 9,0 MPa (a)
4/ Mechanical regulation	Exhaust steam pressure	up to 0,07-1,4 MPa (a)
5/ Driven machine	Inlet steam temperature	up to 550 °C
6/ Base frame	Controlled extraction after the I. Stage	



- This type of microturbine may be used with gearbox or without gearbox with possibility of more blade stages. Mechanical and electronic regulation is suitable for this type of turbine.
- Microturbine consists of welded base frame providing support for turbine body, drive machine (generator, pump or second gearbox for sugar-cane mill), oil system and oil tank. Rotor is placed between two friction bearings. Flexible coupling provides connection of rotor shaft and gearbox. Mechanical face seals provided reduce steam leaks effectively and also conducts seal steam.
- Shaft speed is automatically governed by microturbine depending on the driven machine requirements. No regulation of exhaust steam pressure for mechanical actuators.

TRm

1/ Steam inlet	Power output	up to 1 200 kW
2/ Steam outlet	Speed	5 000 rpm
3/ Turbine casing	Inlet steam pressure	up to 6,0 MPa (a)
4/ Mechanical regulation	Exhaust steam pressure	up to 0,9 MPa (a)
5/ Driven machine	Inlet steam temperature	up to 450 °C
6/ Base frame		





AZR 450

1/ Nominal size	DN100÷DN400 / DN350÷DN1400
2/ Nominal pressure	up to PN100
3/ Max. Temperature [°C]	450
4/ Valve body	Angle
5/ Connection	Weld end / Flange
6/ Standard	ČSN, EN (connection acc. To ANSI, GOST)
7/ Characteristic	Linear / Equal percentage
8/ Body material	Cast: GP240GH, G17CrMo5-5 Forged: P245GH, 13CrMo4-5, 16Mo3
9/ Kvs [m³/h]	125÷4000
10/ Actuator	Electric, Pneumatic, Hydraulic
11/ Valve plug	Unbalanced / Balanced
12/ Application	Reducing stations; Bypass stations



AZR 610

1/ Nominal size	DN100÷DN400 / DN350÷DN1400
2/ Nominal pressure	up to PN400
3/ Max. Temperature [°C]	610
4/ Valve body	Angle
5/ Connection	Weld end / Flange
6/ Standard	ČSN, EN (connection acc. To ANSI, GOST)
7/ Characteristic	Linear / Equal percentage
8/ Body material	Cast: G17CrMo5-5, G17CrMoV5-10 Forged: 13CrMo4-5, 10CrMo9-10, X10CrMoVNb9-1
9/ Kvs [m³/h]	125÷4000
10/ Actuator	Electric, Pneumatic, Hydraulic
11/ Valve plug	Unbalanced / Balanced
12/ Application	Reducing stations; Bypass stations



AZ 23

DN15÷DN500
up to PN500
610
Globe
Weld end / Flange
ČSN, EN (connection acc. To ANSI, GOST)
Linear / Equal percentage
Cast: GP240GH, G17CrMo5-5, G17CrMoV5-10, Forged: P245GH, 13CrMo4-5, 10CrMo9-10, X10CrMoVNb9-1, 16Mo3
0,01÷2800
Electric, Pneumatic, Hydraulic, Hand wheel
Unbalanced / Balanced
Regulation of injected water, seal steam and (water) level in heaters; condensate regulation (level, recirculation)

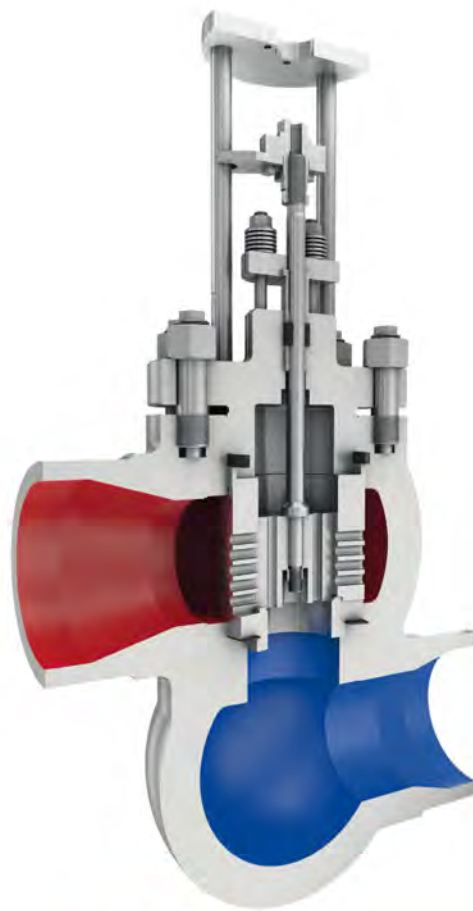

AZZ 450

DN80 - DN1400
up to PN250
450
„Z“ form
Weld end / Flange
ČSN, EN (connection acc. To ANSI, GOST)
Linear / Equal percentage
Cast: GP240GH, G17CrMo5-5 Forged: P245GH, 13CrMo4-5, 16Mo3
125÷4000
Electric, Pneumatic, Hydraulic
Unbalanced / Balanced
Feed valve, Bypass stations

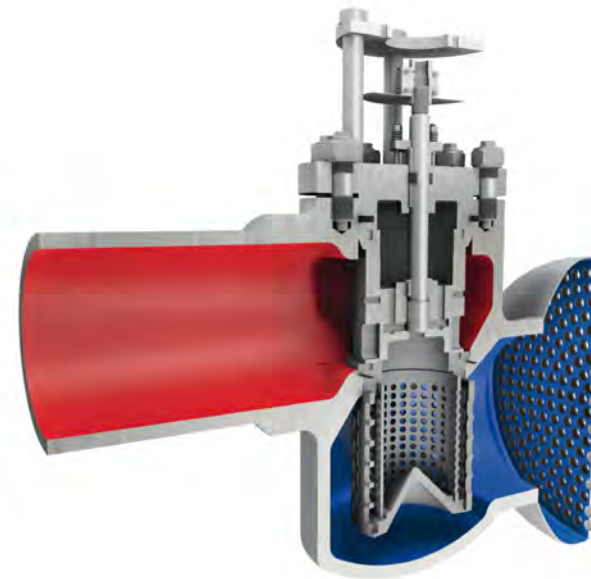

AZZ 610

DN80 - DN1400
up to PN500
610
„Z“ form
Weld end / Flange
ČSN, EN (connection acc. To ANSI, GOST)
Linear / Equal percentage
Cast: G17CrMo5-5, G17CrMoV5-10 Forged: 13CrMo4-5, 10CrMo9-10, X10CrMoVNb9-1
125÷4000
Electric, Pneumatic, Hydraulic
Unbalanced / Balanced
Bypass stations

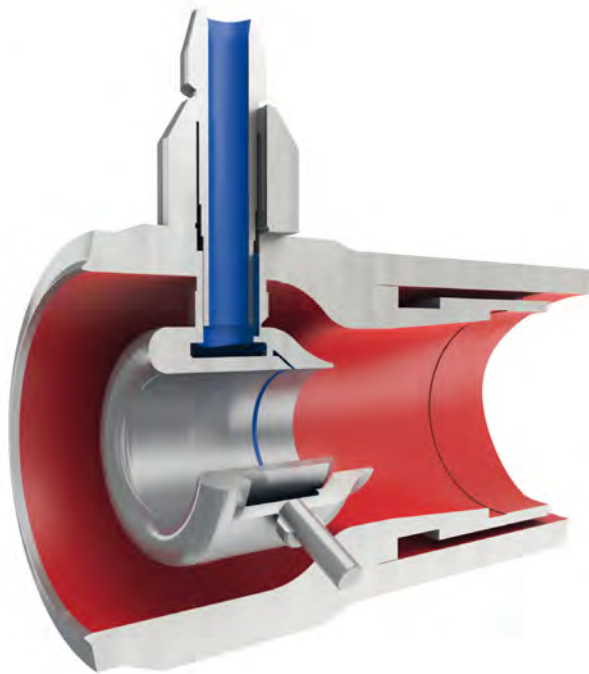

VCHA

1/ Nominal size	DN100÷DN700	DN25÷DN200
2/ Nominal pressure	PN16÷PN400	PN16÷PN100
3/ Max. Steam temperature	610	550
4/ Connection	Weld end / Flange	Weld end / Flange
5/ Body material	P245GH, 16Mo3, 13CrMo4-5, 10CrMo9-10, X10CrMoVNb9-1	P245GH, 16Mo3, 13CrMo4-5, 10CrMo9-10, X10CrMoVNb9-1
6/ Standard	ČSN, EN (connection acc. To ANSI, GOST)	ČSN, EN (connection acc. To ANSI, GOST)
7/ Cooling system	Aerodynamic	Aerodynamic
8/ Operating range	10% ÷ 100% of rated flow	15% ÷ 100% of rated flow
9/ Min. steam temperature after cooling	Saturation temp. + 7 – 11 °C	Saturation temp. + 7 – 11 °C
10/ Min. Δp injected water and cooled steam [bar]	2	0,7
11/ Application	Reducing and Cooling (Desuperheating) stations; Bypass stations; Steam boiler (superheaters, reheaters)	Reducing and Cooling (Desuperheating) stations; Bypass stations; Seal steam; Steam for technological processes

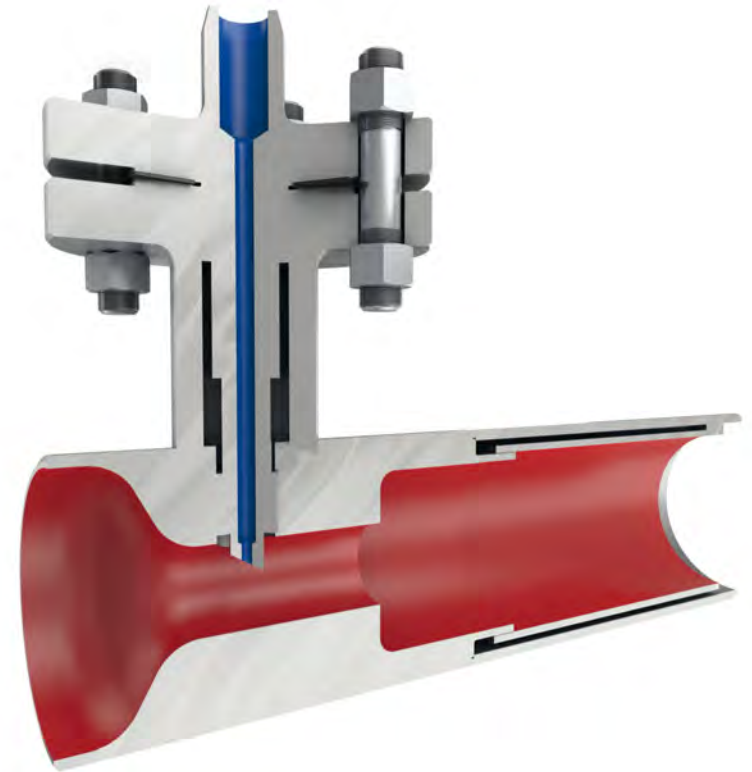

VCHT

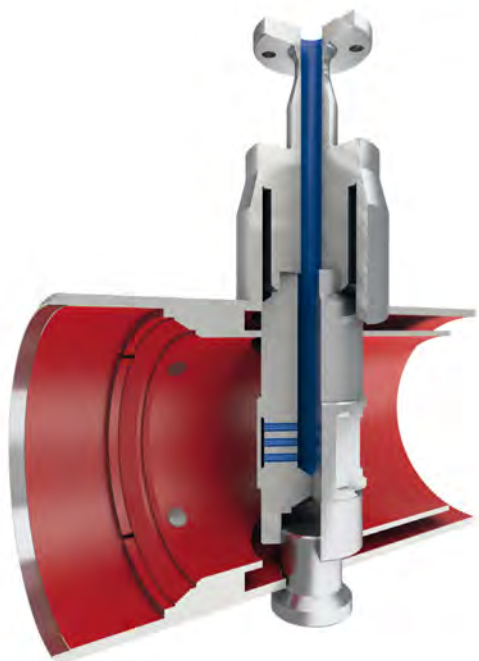

PRCH

DN250÷DN500

PN16÷PN100

550

Weld end / Flange

P245GH, 16Mo3, 13CrMo4-5, 10CrMo9-10

ČSN, EN (connection acc. To ANSI, GOST)

Aerodynamic

15% ÷ 100% of rated flow

Saturation temp. + 7 – 11 °C

1

Reducing and Cooling (Desuperheating) stations; Bypass stations; Steam for technological processes

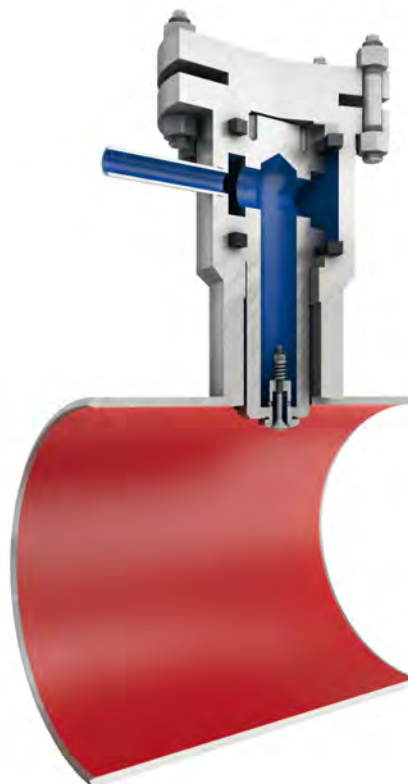

TCH-RT

DN125÷DN1400

PN16÷PN160

610

Weld end / Flange

P245GH, 16Mo3, 13CrMo4-5, 10CrMo9-10, X10CrMoVNb9-1

ČSN, EN (connection acc. To ANSI, GOST)

Spray nozzles

3% ÷ 100% of rated flow

Saturation temp. + 7 – 11 °C

5

Reducing and Bypass stations; Turbine backpressure for low pressure losses

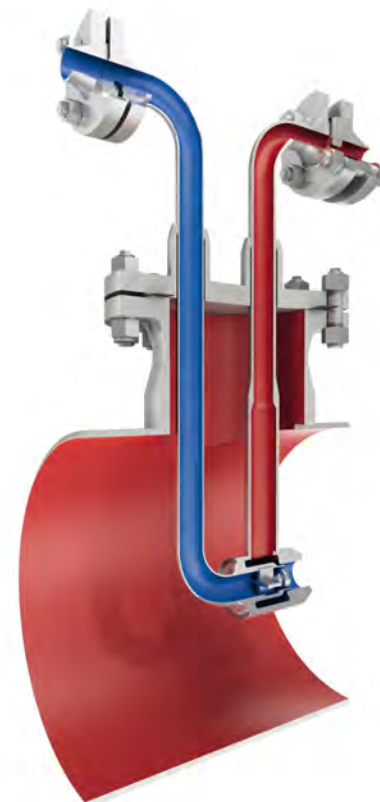

CHP

DN200÷DN700

PN16÷PN160

610

Weld end / Flange

P245GH, 16Mo3, 13CrMo4-5, 10CrMo9-10, X10CrMoVNb9-1

ČSN, EN (connection acc. To ANSI, GOST)

Atomizing steam

3% ÷ 100% of rated flow

Saturation temp. + 7 – 11 °C

3

Reducing and Cooling (Desuperheating) stations; Turbine extraction; Turbine backpressure; High flow range of steam and cooling water

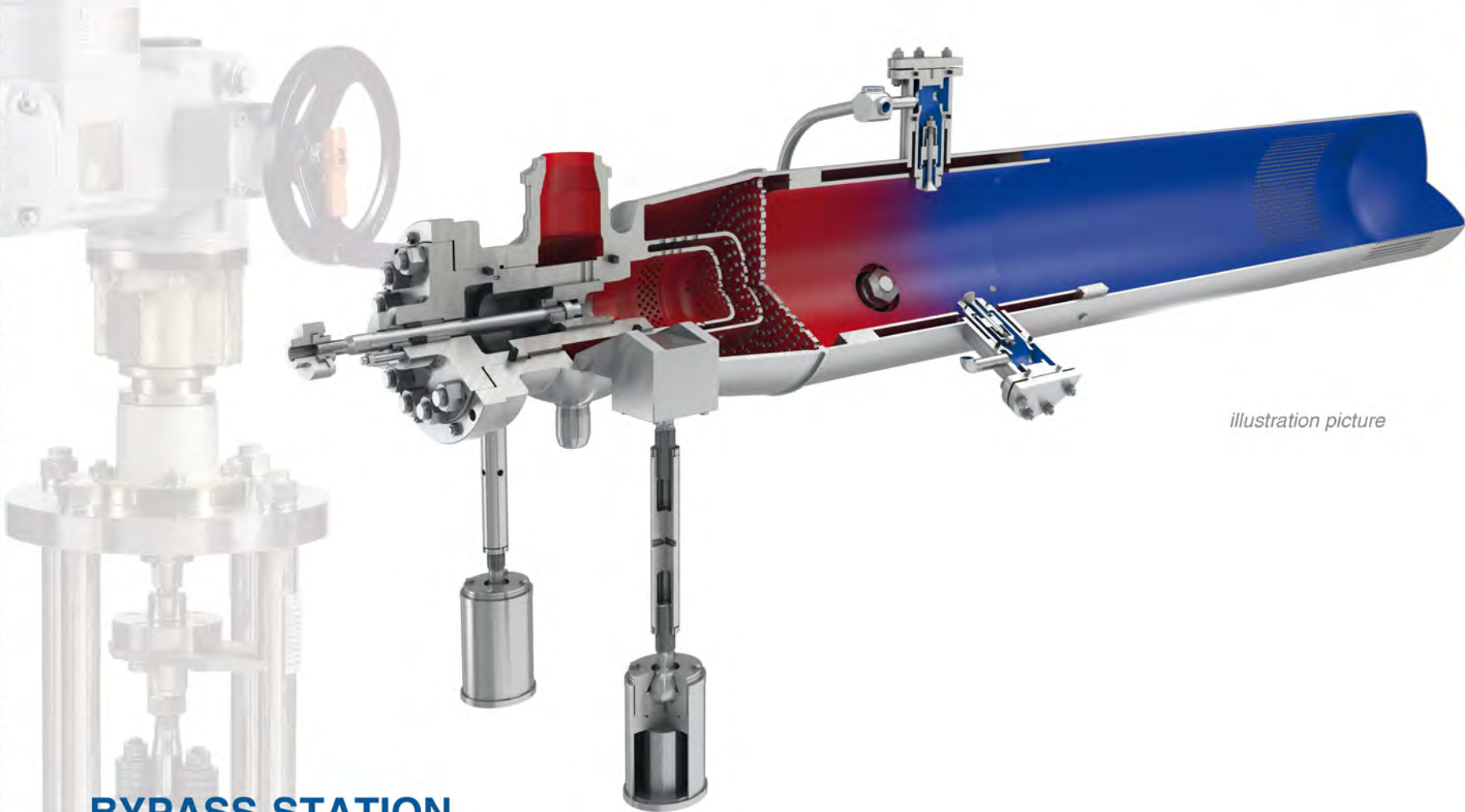
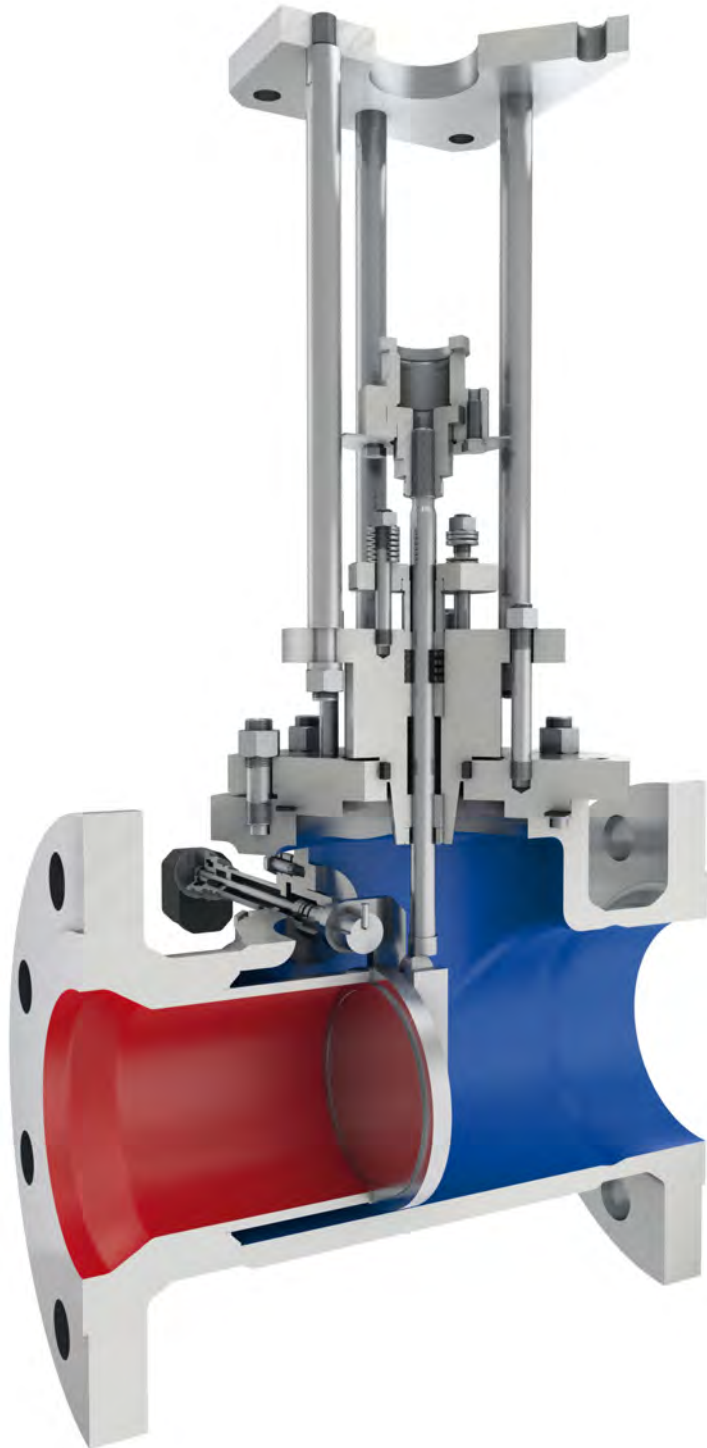

illustration picture

BYPASS STATION

1/ Nominal size	DN100÷DN400 / DN350÷DN1400
2/ Nominal pressure	up to PN500
3/ Max. Temperature [°C]	610
4/ Valve body	Angle, „Z“ - form
5/ Connection	Weld end / Flange
6/ Standard	ČSN, EN (connection acc. To ANSI, GOST)
7/ Characteristic	Linear / Equal percentage
8/ Body material	Cast: GP240GH, G17CrMo5-5, G17CrMoV5-10 Forged: P245GH, 13CrMo4-5, 10CrMo9-10, X10CrMoVNb9-1
9/ Kvs [m³/h]	up to 6300
10/ Actuator	Electric, Pneumatic, Hydraulic





EXTRACTION CHECK VALVES – FGT

1/ Nominal size	DN80-DN1200
2/ Nominal pressure	up to PN100
3/ Max. Temperature [°C]	up to 550
4/ Connection	Weld end / Flange
5/ Standard	ČSN, EN (connection acc.to ANSI, GOST)
6/ Body material	GP240GH, G17CrMo5-5, G17CrMoV5-10
7/ Actuator	Pneumatic / hydraulic / self-acting (without actuator)
8/ Application	Turbine extraction system

Design Engineering

of pipeline systems in power generation and industry

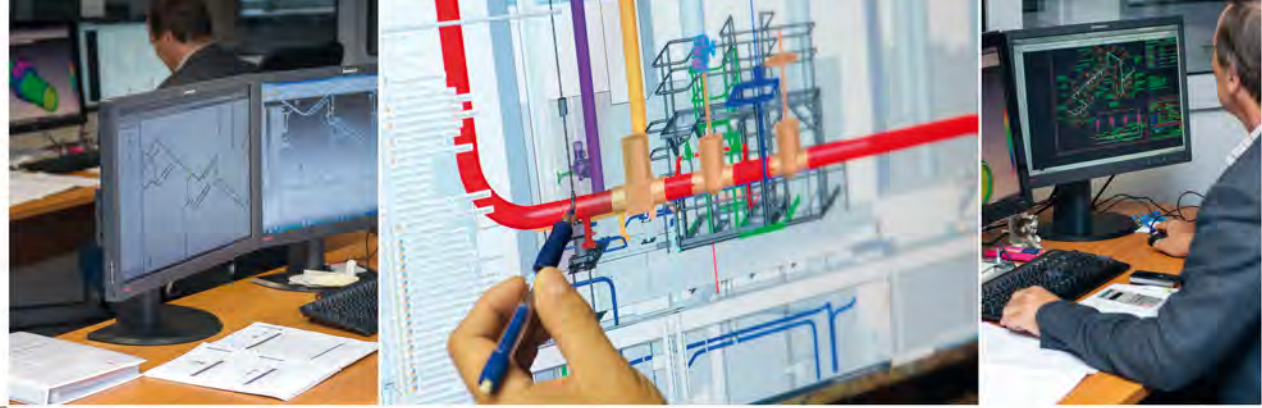

- **technical feasibility study**, ideal balance design of energy equipment and units,
- **comprehensive project documentation** for planning permission (basic design), building design (detail design) and actual design of technological equipment and operation sets for power plants, heating plants and industrial estates in compliance with valid law and technical regulations,
- **project documentation of repairs and reconstructions of selected technological equipment** and operation sets of nuclear power plants classified as BT2 and BT3 acc. to Notice 132/2008 in conformity with requirements of Notice 309/2005,
- **3D design and space visualization** of technological equipment and pipeline systems including safety valves exhausts, steam trap, draining and air-vent in 3D CAD Solid Edge and Smap3D Plant Design,
- **calculation, piping and instrumentation diagram/drawing showing pipeline components**, valves, energy equipment and instrumentation MaR including position of pipeline and auxiliary steel constructions,
- **design and calculation verification of unnormalized pipeline components** through SW ANSYS PROFESSIONAL,
- **piping Flexibility Analysis** through SW CAESAR II
- **design of pressure and pressure-free vessels**, reducing, desuperheating (cooling) and bypass stations including safety pressure equipment in compliance with valid law,
- **project documentation of pressure tests and cleaning processes** after installation,
- **control algorithm design for regulation**, warming-through and commissioning of technological equipment, creation of operating regulations,
- **G-Team ACADEMY** – trainings and seminars.

Design and control of unnormalized pipeline components

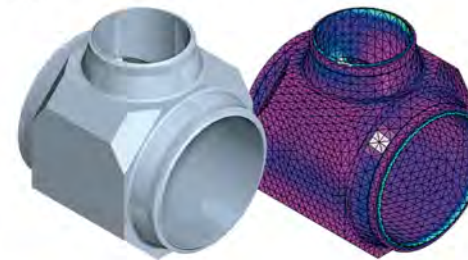

ANSYS

Design and documentation of auxiliary steel structures

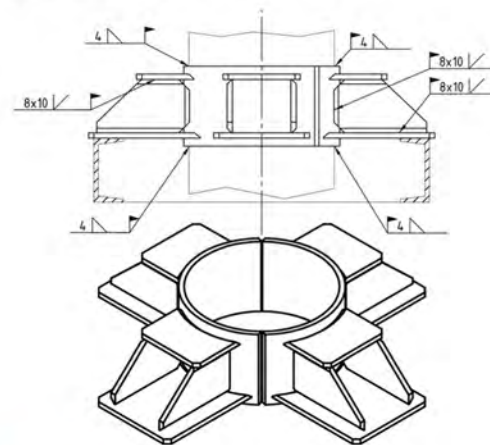

SOLID EDGE



Isometric drawings for pipeline

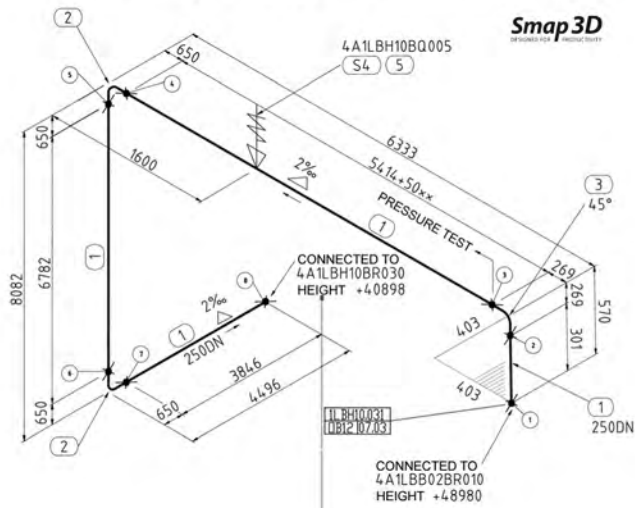

Balance and functional scheme

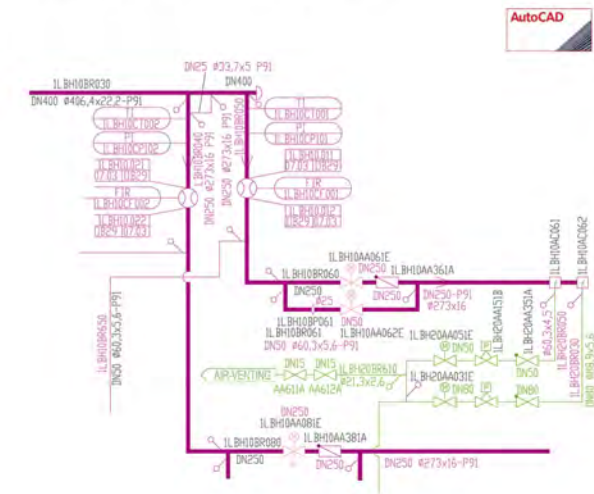

Flexibility and thermal expansion analysis

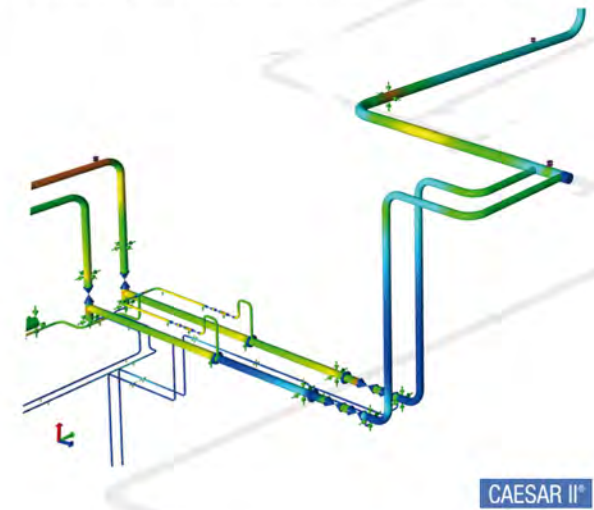

Experimental and Development Department

- **Control valves testing**

testing pipe route designed according to ČSN EN 60534-2-3 provides flow characteristics and nominal flow coefficients kvs of control valves - DN15 – DN150, up to $k_v = 100 \text{ m}^3/\text{h}$.

- **Desuperheaters testing**

- testing route designed for nozzle optimization of mixing cooler of superheated steam,
- practical verification of newly designed desuperheaters with possibility of size measuring of atomized drops,
- testing parameters of reduced inlet steam – temperature up to $240 \text{ }^\circ\text{C}$, pressure approx. 12 bar(g), amount up to 4 (± 6) t/h,
- testing parameters of inlet cooling water – temperature $15\pm 100 \text{ }^\circ\text{C}$, pressure up to 20 bar(g), amount up to 2,0 t/h.

- **Microturbine testing**

- testing route designed for verification of TR service availability before despatch to customer (check of operating vibrations and oil temperature in bearings),
- testing parameters of inlet steam – temperature $240 \text{ }^\circ\text{C}$, pressure 12 bar(g), flow 4 (± 6) t/h.

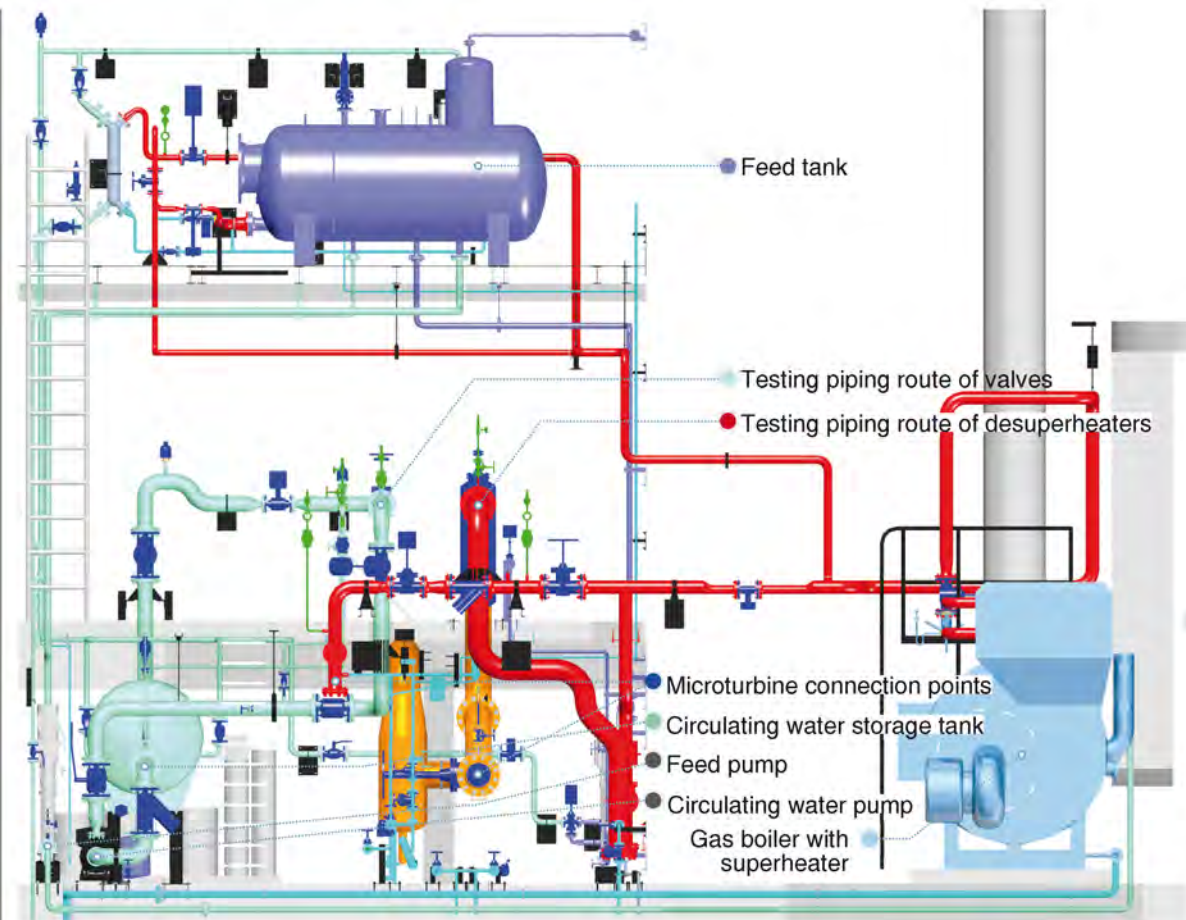

Equipment for power and heat generation industry

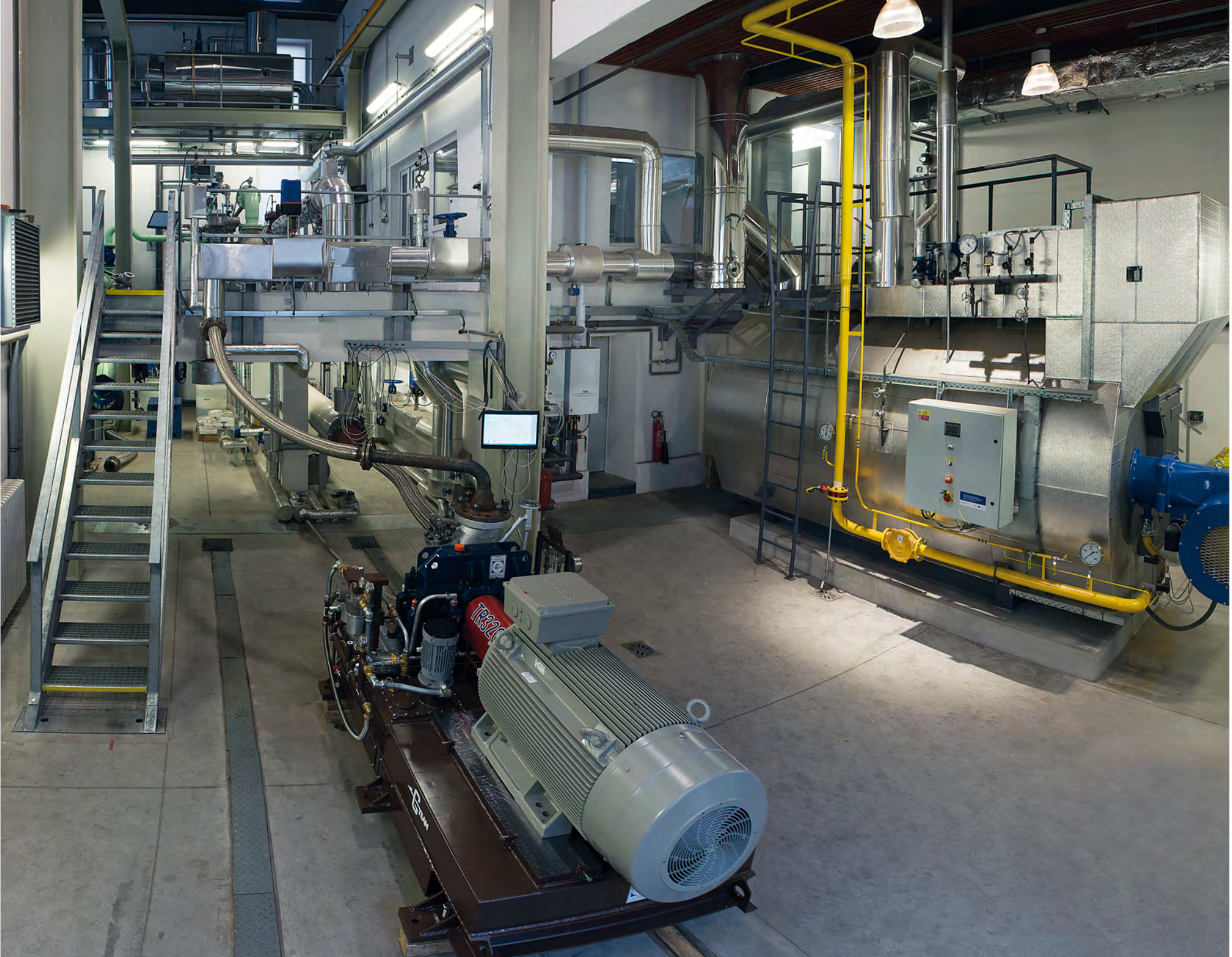

Installation



- **Steam turbine installation**

- Condensing steam turbines
- Backpressure steam turbines
- Microturbines
- Gearbox installation
- Heavy manipulation into and in installation area

- **Turbine Current and overhaul repair**

- Spare parts supply

- **Generator installation**

- Air-cooled generators
- Hydrogen-cooled generators

- **Pipeline system installation**

- Pipeline installation from P91, noncorrosive and carbon material
- Pipeline oil systems
- Water-steam pipeline
- High-pressure hydraulic pipeline
- Industrial gas system
- Installation and adjustment of control valves
- Installation and adjustment of servo-actuators

- **Additional installations**

- Installation of hydrogen system
- Installation of oil system
- Installation of integrated oil system
- Installation of pumps and feed pumps
- Installation of coolers (desuperheaters)
- Installation of heaters, tanks and pressure vessels
- Installation of steam turbine condensers
- Measurement of energy quantities
- Vibration and movement of rotary machines
- Diagnostics of steam traps operation



Equipment for power and heat generation industry

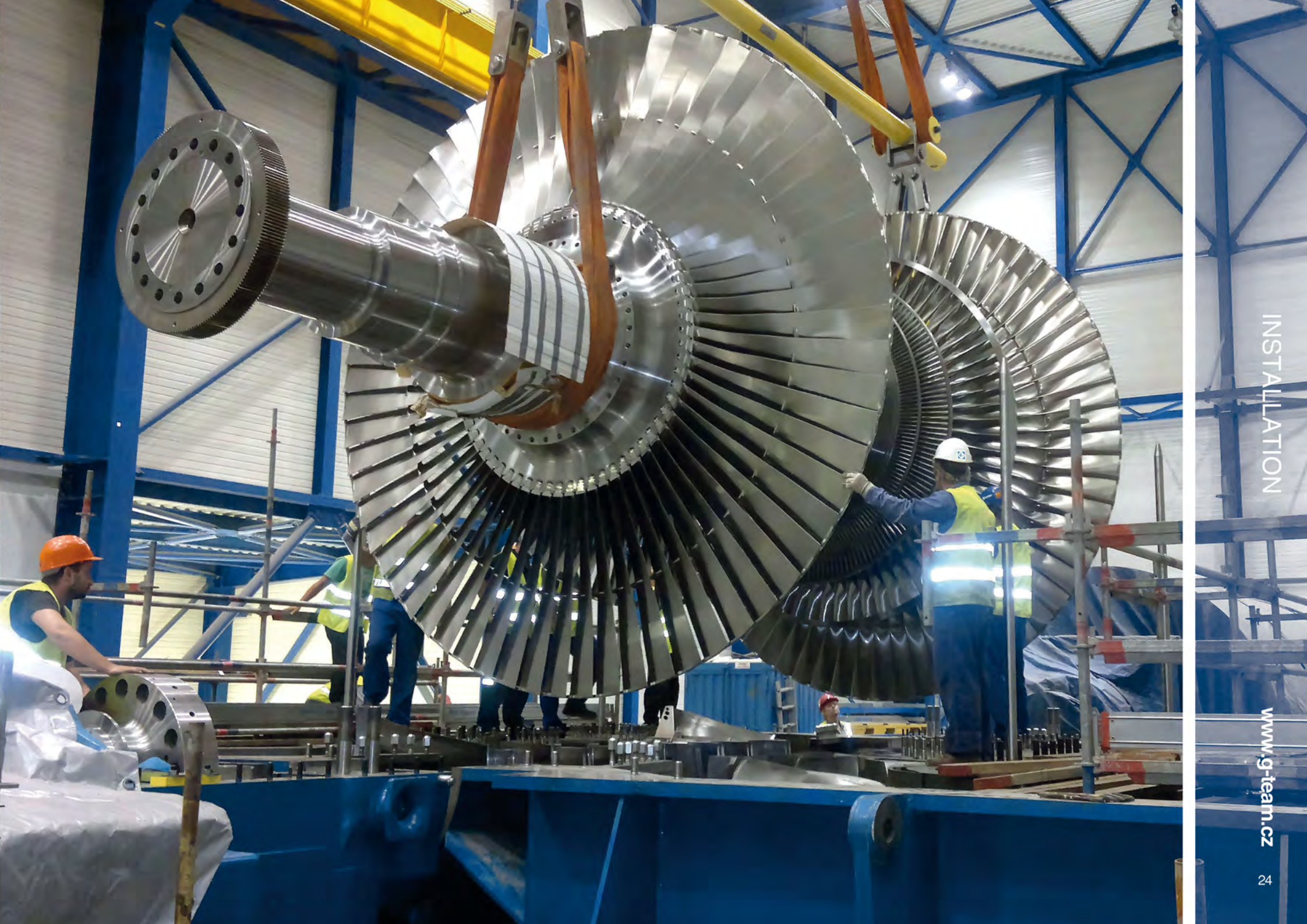

INSTALLATION

www.g-team.cz

Production



G-Team a.s. provides manufacturing its own products without dependence on further suppliers. Manufacturing process is controlled by information system from drawing documentation through technology, standardization and planning up to workshop with monitoring of each manufacturing procedure including bar-code reader terminals.

- **Milling (Machining)**

G-team a.s. provides milling on modern CNC machines. CAM system ensures programming with 3D simulation. CNC machines allow milling process of hardness up to 400HV.

Machine components:

5-axis CNC milling machines

CNC lathes

CNC drilling machine

Conventional machines – drilling machine, carousel, lathes, milling machines, grinders

- **Welding procedure:**

Methods: TIG, MIG, MAG, MMA

certification according to EN-ISO 3834-2

meets the requirements of Not. 132/2008 up to BT2 category incl.

- **Heat treatment:**

Digital annealing furnaces

Local preheating and digital resistance annealing

- **Sandblasting**

- **Varnishing**



Equipment for power and heat generation industry



PRODUCTION

www.g-team.cz



Equipment for power and heat generation industry

Office

Petrská 2
110 00 Prague 1
Czech Republic
www.g-team.cz

Headquarters and the Production

Červený mlýn
330 23 Pilsen – Vochov
Ph: +420 377 822 401
+420 377 822 410
Fax: +420 377 822 425
E-mail: gteam@g-team.cz



Gold Medal - MSV
Brno 2009 (TR Hi150)



ISO 9001:2008



ČSN EN ISO 14001:2005



ČSN EN ISO 3834 –
2:2006



Workplace Conditions
Assessment (WCA)



Approved Partner ČEZ